

EE13-15外壳

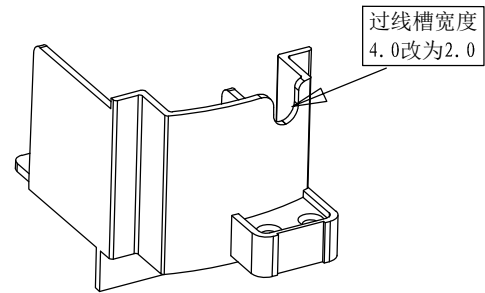
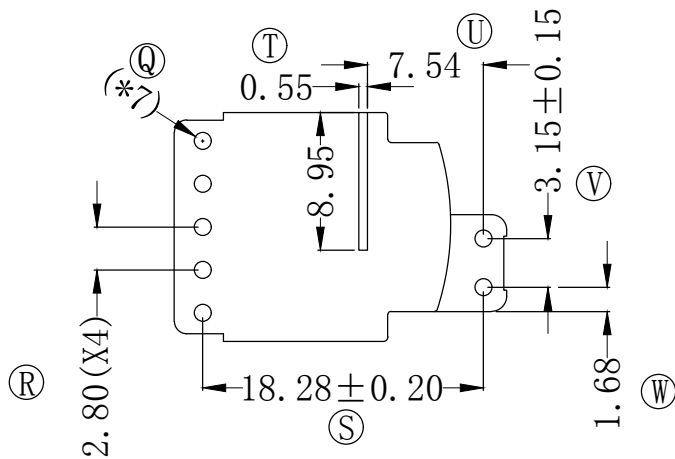
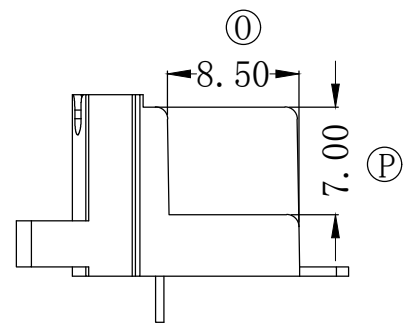
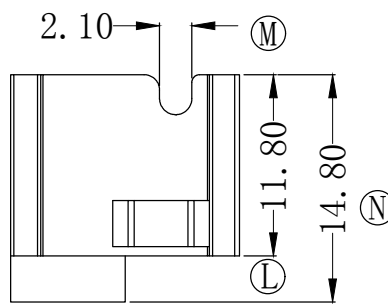
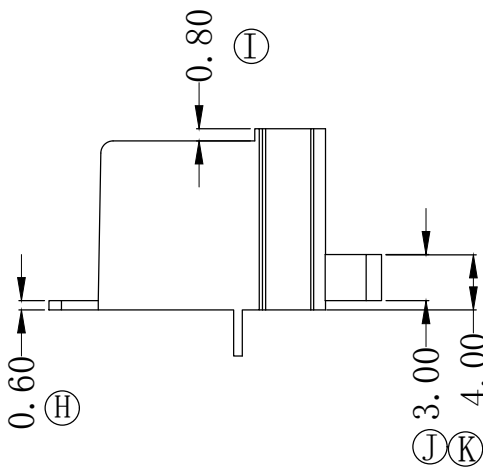
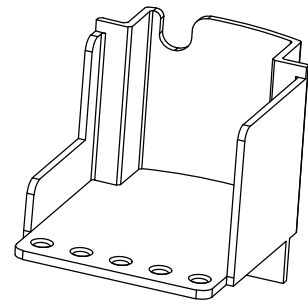
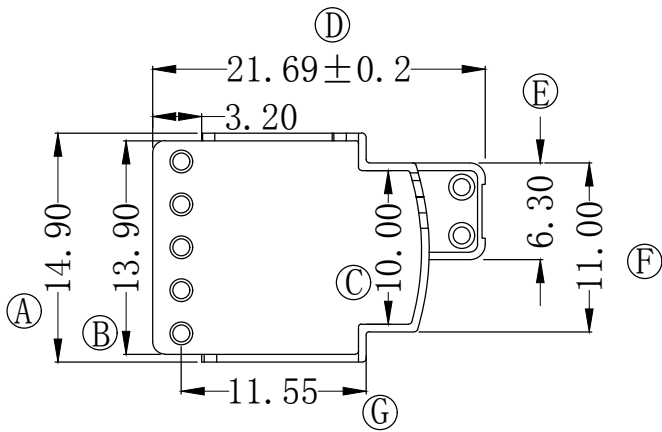

东莞市汇泉塑胶五金有限公司
DONGGUAN HUIQUAN PLASTIC HARDWARE CO., LTD

Address: 东莞市樟木头镇樟洋银洋路22号2栋

Tel: 0769-89978391

MP: 18988725701-18988725702

E-mail: cqchao168@163.COM

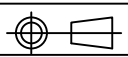
TITLE:	EE13-15外壳	SCALE:	FULL
DRAWING NO:	EE13-16	UNIT:	m/m
MATERIAL:	PLASTIC	UL REC:	94V-0
PIN MATERIAL:		TOLERANCE	
 PIN PITCH ±0.20	DATE: 2022. 07. 15	ANGLE	±1°
			0<L≤4: ±0.1 4<L≤16: ±0.2 16<L≤63: ±0.3